

Dual Audio Potentiometers Deliver Power Savings for Consumer Audio Devices

The new emphasis on power-saving technology means that the low power requirements typical of battery-powered systems are also now desirable on non-battery powered devices. Consumer audio devices can take advantage of 'green' products like stereo volume controllers that integrate a wide range of features and deliver low power. These features can include a push button interface for volume control, built-in click and pop suppression, a $V_{CC}/2$ reference and audio detection circuitry, all in a space saving 4x4 QFN package. Maximizing battery life, while keeping a low cost bill of materials (BOM) and minimal component count, is often a primary objective when designing an audio docking station. Using single supply op amps can simplify design and reduce BOM cost, but require a $V_{CC}/2$ reference. In addition to any volume control and signal processing hardware, special hardware is often added for audio detection and standby mode implementation. It can have a special low power standby mode with a built-in flag output, which allows it to signal to the rest of the system when no audio is present on its input.

Applications include CD/DVD/MP3 players, gaming consoles, notebook PCs, GPS systems, audio docking stations, and others. We will investigate an example application: a state-of-the-art dual audio potentiometer used for stereo volume control in a portable audio docking station.

While the exact makeup of an audio docking station varies from one manufacturer to another, there are several commonalities. A typical device will have an interface to an external audio player or an auxiliary audio source. Once audio is in the device, it is usually filtered, equalized and then attenuated by a volume controller to set the desired volume. Additional signal processing can perform a variety of functions. For example, it can boost or attenuate certain frequency ranges before the audio is fed through the power amplifier to the speakers. Power management hardware is also included to provide necessary voltage rails and to help implement low power standby modes. A block diagram of a typical docking station is shown in Figure 1.

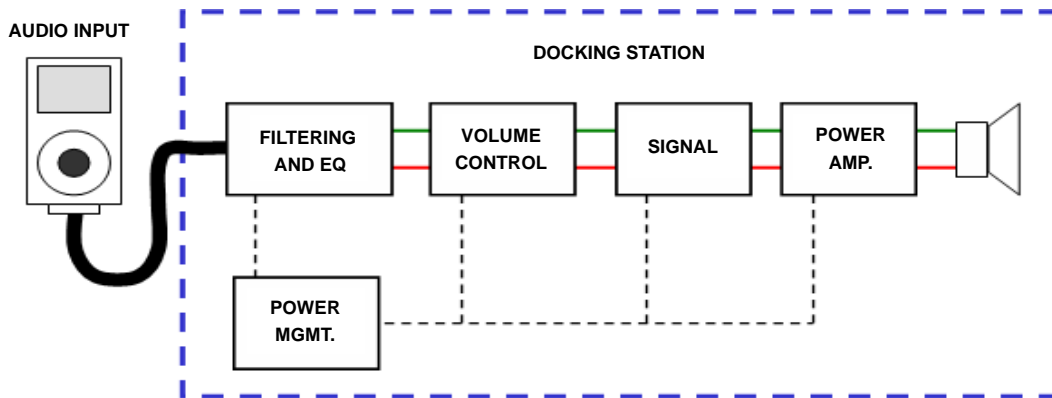

FIGURE 1. AUDIO DOCKING STATION BLOCK DIAGRAM

Application Note 1701

The optimal stereo volume controller will operate from a 2.7V to 5.5V supply, which allows operation from 2 or 3 alkaline cells, or a regulated power rail. For volume control, the amp should be able to use two digitally controlled potentiometers, each with buffered output wipers. A simple up/down push button interface can control the volume, and internal de-bounce circuitry prevents the volume level from changing inadvertently when a push button has been low for less than 15ms. Ideally, the attenuation range of the volume control hardware is from 0dB to -70dB, with a mute level of -90dB. Audio performance for consumer-grade devices should provide a THD+N level of 0.01%@1kHz and cross talk isolation between channels of -100dB@1kHz. Channel-to-channel variation should be ± 0.1 dB, allowing for precise impedance matching between channels. Click and pop noise during volume transitions, a common problem with audio DCPs, is minimized using internal zero-crossing hardware.

Low power standby modes are enabled quickly and easily by audio detection and standby mode circuitry. The audio detection circuitry monitors all audio inputs (in this case, two), and signals with a flag when no audio input is detected. It is also beneficial to have a low power hibernation mode, in order to bring current draw down to $<400\mu\text{A}$ and preserve power. The flag output can also be used as an external system flag, automatically putting the system into standby mode. This lowers overall power draw of the device, increasing battery life or, in the case of non-battery powered devices, reducing power loss. Of course, when audio is again present on the input, the flag resets, waking the system from its low power mode. To reduce the possibility of audible hiss while in standby, the left and right audio inputs should be disconnected from their DCP arrays and each wiper moved to its maximum attenuation level.

Experimental Data

For demonstration purposes, we have integrated an evaluation board with an off-the-shelf audio docking station. The docking station originally used a mechanical potentiometer for volume control, external volume control buffers, a discretely implemented audio detection circuit and a discretely implemented $V_{CC}/2$ bias generator. A small microcontroller was used to put the system into standby mode when no audio was present on the input. The internal organization of the docking station is similar to that shown in Figure 1.

Before integrating the controller into the docking station, it's important to document the standby operation of the docking station. Figure 2 shows the removal of audio from the docking station's input and its transition into standby mode. In the scope shot, CH1 was the audio input to the docking station and CH2 represented the output of the docking station's audio detection circuitry. When audio was removed, CH2 immediately transitioned low. This input was then fed to a microcontroller, which implemented a timeout feature that put the docking station into sleep mode after ~ 180 s. As the scope shot shows, the input current went from $\sim 50\text{mA}$ with no audio present, down to less than 2mA in standby.

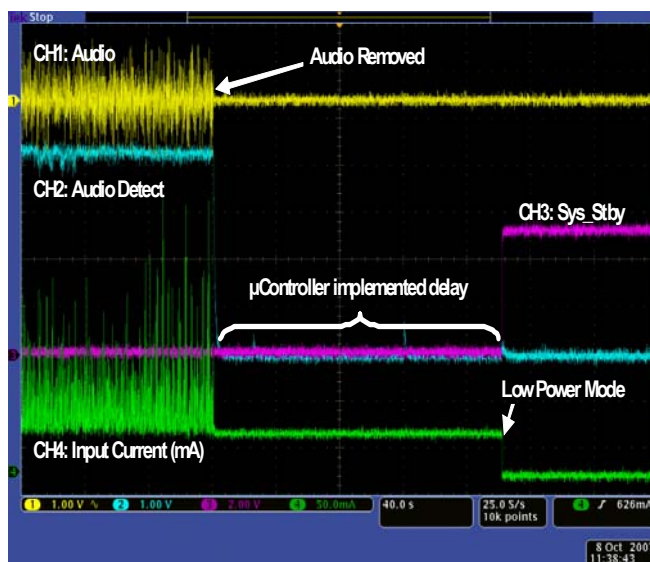

FIGURE 2. LOW POWER MODE WITH DISCRETE SOLUTION

Then, the evaluation board was integrated with the docking station, replacing the mechanical potentiometer, volume buffers and $V_{CC}/2$ reference, and offloading the time delay functionality from the microcontroller. Figure 3 shows the docking station transitioning into low power mode with the ISL22102 as the example device.

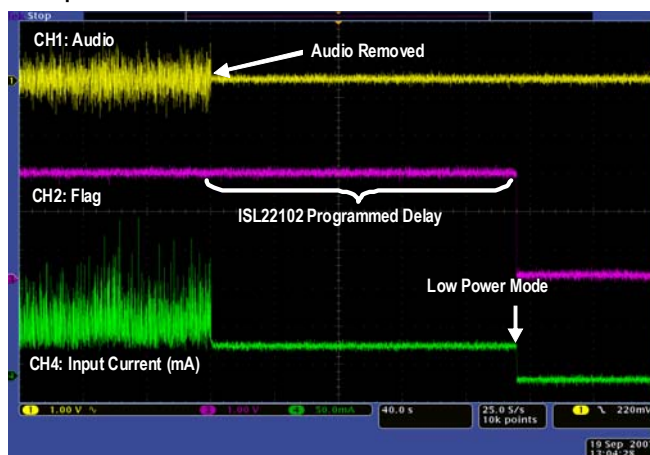

FIGURE 3. LOW POWER MODE WITH ISL22102

As Figure 3 shows, the transition of the docking station into sleep mode was nearly identical. The power draw of the docking station went from $\sim 50\text{mA}$ with no audio present on the input to less than 2mA in standby. The use of the device as a volume controller in place of a discretely implemented solution reduces the BOM by a total of 42 components, while maintaining low power mode functionality. Table 1 shows the component reduction broken down by part and function.

Overall, the growing emphasis on green technology is having a good effect on the entire audio market, plugged and unplugged. Parts like the ISL22102 now sport low power standby modes and hibernation modes to keep from wasting power. These features complement the high-quality audio performance customers demand, creating an integrated solution for a formerly power-hungry audio docking system.

Application Note 1701

TABLE 1. BOM SAVINGS vs DISCRETE SOLUTION

Sub Circuit	Resistor	Capacitor	FETs	Op-Amps	Diodes	Total
Vcc/2 Bias	2	2	0	1	0	5
Volume Control	1	0	0	0	0	1
Buffer Amps	8	5	0	2	0	15
Audio Detect	6	5	1	1	2	15
Standby	2	2	2	0	0	6
					Total:	42

Intersil Corporation reserves the right to make changes in circuit design, software and/or specifications at any time without notice. Accordingly, the reader is cautioned to verify that the Application Note or Technical Brief is current before proceeding.

For information regarding Intersil Corporation and its products, see www.intersil.com